

⚡ Specifications

Nominal Voltage (V)

12V

Nominal Capacity

10 hour rate	(20A to 10.80V)	200Ah
5 hour rate	(34A to 10.20V)	170Ah
1 hour rate	(120A to 9.60V)	120Ah
1 C	(200A to 9.60V)	126.7Ah

Weight

Approx. 68kg(150Lbs.)

Internal Resistance (at 1KHz)

Approx. 3mΩ

Maximum Discharge Current for

5 seconds: 1200A

Charging Methods at 25°C(77°F)

Cycle use:	
Charging Voltage	14.4 to 15.0V
Coefficient	-5.0mV/°C/cell
Maximum Charging Current	60A
Standby use:	
Float Charging Voltage	13.5 to 13.8V
Coefficient	-3.0mV/°C/cell

Operating Temperature Range

Charge	-15°C(5°F)	to	40°C(104°F)
Discharge	-15°C(5°F)	to	50°C(122°F)
Storage	-15°C(5°F)	to	40°C(104°F)

Charge Retention (shelf life) at 20°C(68°F)

1 month	98%
3 month	94%
6 month	85%

Case Material

ABS UL94 HB
Option: Flammability resistance of (UL94 V-0)



⚡ Dimensions

Length (L)	522±3 (20.55±0.12)
Width (W)	238±3 (9.37±0.12)
Height (H)	219±3 (8.62±0.12)
Overall Height (HT)	224±3 (8.82±0.12)
Terminal	F18

Description of torque value of hardware for the terminals:

Recommended torque value	M8: 12 N-m (122 kgf-cm)
Maximum allowable torque value	M8: 20 N-m (204 kgf-cm)

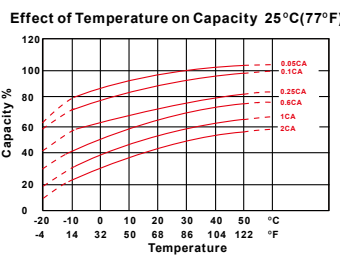
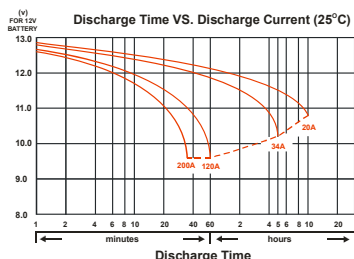
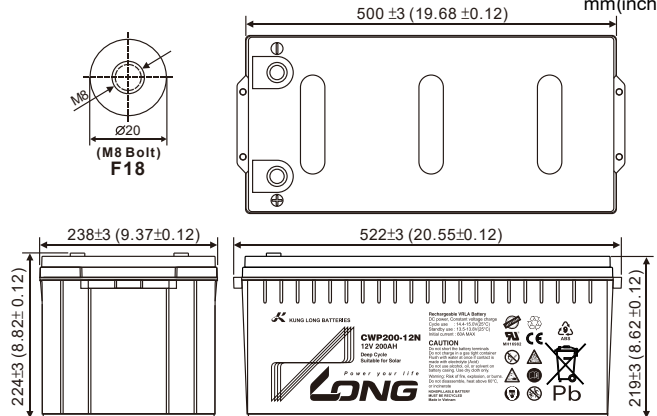

Relationship Between Temperature and Charging Voltage

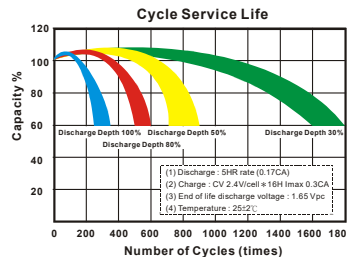
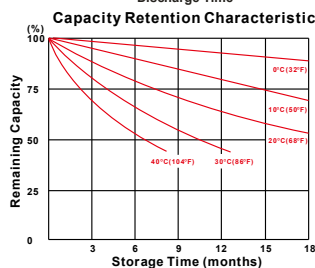
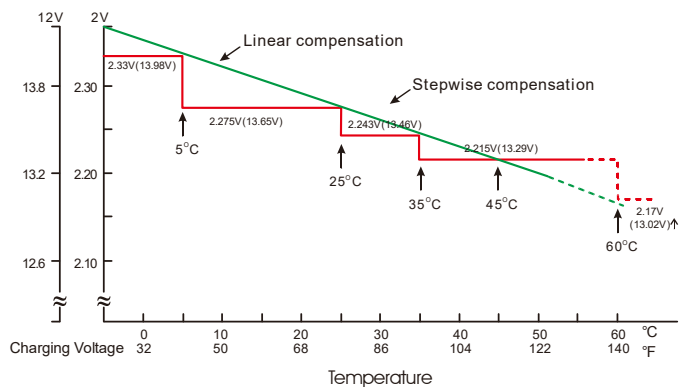

221024-1B