

⚡ Specifications

Nominal Voltage(V)

12V

Nominal Capacity

20 hour rate	(9.5A to 10.50V)	190Ah
10 hour rate	(19A to 10.80V)	190Ah
5 hour rate	(32.3A to 10.50V)	161.5Ah
1 hour rate	(114A to 9.60V)	114Ah

Weight

Approx. 59.5kg(131Lbs.)

Internal Resistance (at 20°C)

Approx. 3.5 mΩ

Maximum Discharge Current for (at 20°C)

5 seconds: 1140A

Short Circuit Current (A) IEC60896-21-22

3400 A

Charging Methods at 25°C(77°F)

Cycle use:	
Charging Voltage	14.4 to 15.0V
Coefficient	-5.0mV/°C/cell
Maximum Charging Current :	57A
Standby use:	
Float Charging Voltage	13.5 to 13.8V
Coefficient	-3.0mV/°C/cell

Operating Temperature Range

Charge	-10°C(14°F)	to	60°C(140°F)
Discharge	-20°C(-44°F)	to	60°C(140°F)
Storage	-20°C(-4°F)	to	60°C(140°F)

Charge Retention (shelf life) at 20°C(68°F)

1 month	98%
3 month	94%
6 month	85%

Case Material

ABS UL94 HB
Option: Flammability resistance of (UL94 V-0)

Design Life

EUROBAT(20°C) : > 12 YEARS VERY LONG LIFE

Terminal

F18



⚡ Dimensions

Length (L)	558±3 (21.97±0.12)
Width (W)	126±3 (4.96±0.12)
Height (H)	317±3 (12.48±0.12)
Overall Height (HT)	317±3 (12.48±0.12)

Description of torque value of hardware for the terminals:

Recommended torque value	M8: 12N-m (122 kgf-cm)
Maximum allowable torque value	M8: 20N-m (204 kgf-cm)

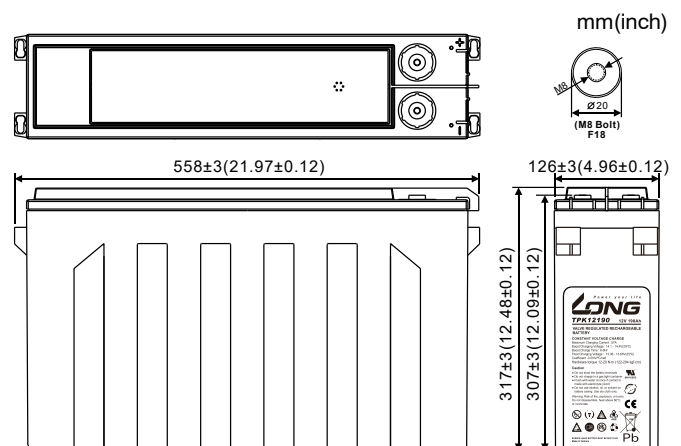

(V) FOR 12V BATTERY Discharge Time VS. Discharge Current (25°C)

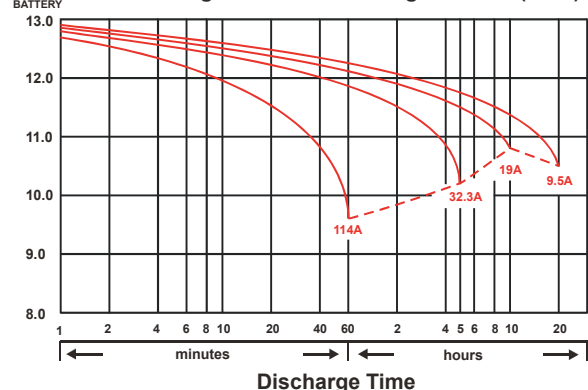

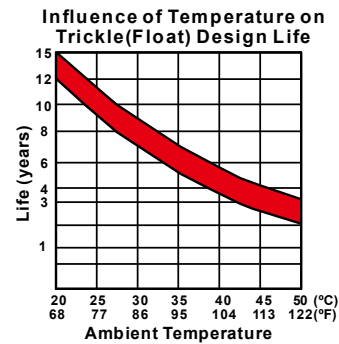
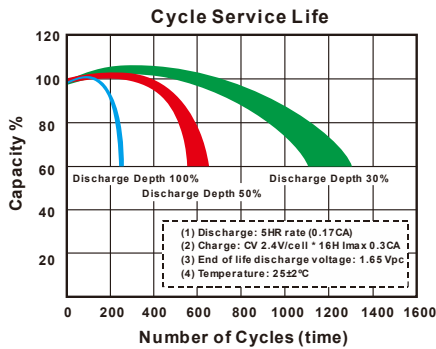
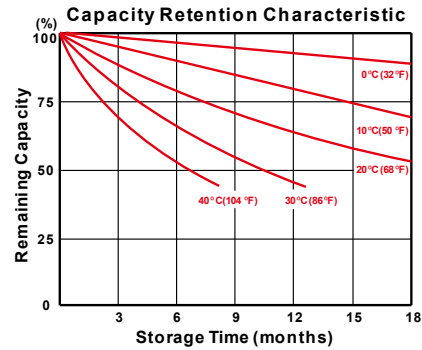
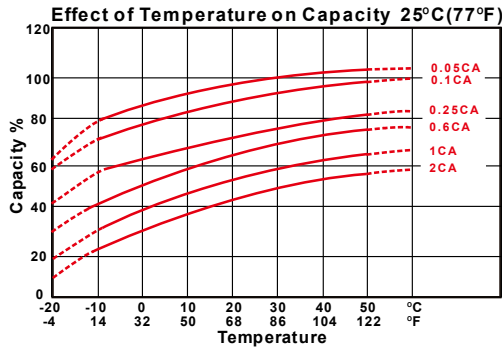

- PERFORMANCE DATA

Discharge Rates in Watts to Various End Voltages at 20°C (68°F)

End Voltage		1.85V	1.80V	1.75V	1.70V	1.67V	1.65V	1.60V
Time								
5	min	693	792	881	921	950	980	1010
10	min	594	673	728	777	827	866	891
15	min	500	569	629	683	708	723	733
30	min	396	426	450	465	470	475	477
60	min	252	260	267	269	270	271	272
120	min	144	152	159	166	171	175	178
180	min	96.7	107	110	112	114	115	116
240	min	77.1	85.0	89.5	90.8	91.6	92.4	93.2
300	min	66.1	68.9	70.3	71.5	72.7	73.5	74.2
480	min	43.8	45.6	46.6	47.3	47.9	48.4	48.7
600	min	34.5	35.7	36.5	36.8	36.9	37.0	37.1
1200	min	16.9	17.7	17.9	18.0	18.0	18.0	18.0

- Discharge Rates in Amperes to Various End Voltages at 20°C (68°F)

End Voltage		1.85V	1.80V	1.75V	1.70V	1.67V	1.65V	1.60V
Time								
5	min	371	436	495	520	545	564	584
10	min	307	366	411	450	477	490	500
15	min	262	302	342	366	386	401	413
30	min	198	228	248	257	267	275	282
60	min	126	136	144	147	149	151	153
120	min	71.2	74.9	77.2	78.7	79.9	81.1	82.2
180	min	50.1	52.8	54.4	55.5	56.6	57.2	57.8
240	min	38.2	40.2	41.5	42.0	42.5	42.9	43.2
300	min	32.1	33.3	34.1	34.6	35.0	35.2	35.5
480	min	21.1	22.3	22.5	22.6	22.7	22.8	22.9
600	min	17.8	19.0	19.0	19.1	19.1	19.2	19.2
1200	min	8.86	9.50	9.68	9.78	9.87	9.87	9.96

All data on the spec. sheet is an average value:

The tolerance range : $X < 6\text{min}$ (+15%~-15%), $6\text{min} \leq X < 10\text{min}$ (+12%~-12%), $10\text{min} \leq X < 60\text{min}$ (+8%~-8%), $X \geq 60\text{min}$ (+5%~-5%)

201124-1C